

Wall Faced Care Toilet Suite

VI202C-G : VI202C / ACCIWRTC / ACC201-4CG

VI202C-B : VI202C / ACCIWRTC / ACC201-6CB

FRONT VIEW

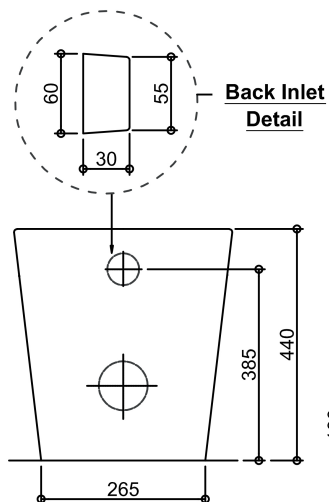

SIDE VIEW

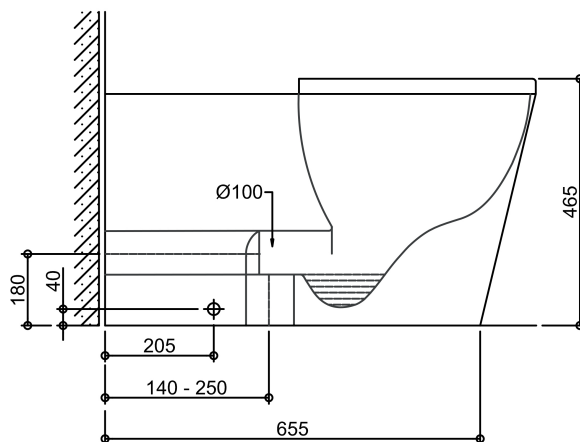

TOP VIEW

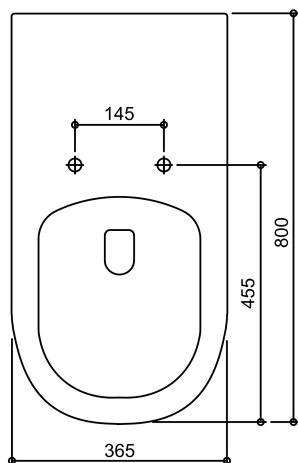

Dimensions in mm

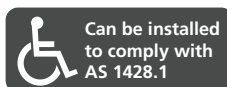

BEFORE YOU BEGIN

Check the product for damage. If the product is damaged return to the store of purchase. Check the product is complete with all components required to install. This product is to only be installed by a licensed plumber, and must be installed in accordance with these instructions, failing to do so will void warranty.

CISTERN INSTALLATION

Refer Oliveri Inwall Cistern (ACCIWRTC) installation guide together with the dimensional pan drawing on this document for correct installation.

You must refer to the INWALL CISTERN INSTALLATION GUIDE in conjunction with this installation document to ensure the toilet suite is installed correctly.

PAN INSTALLATION

WARNING: DO NOT BED THE PAN IN PLACE USING CEMENT, CONCRETE OR SIMILAR MATERIAL, DOING SO WILL VOID THE PRODUCT WARRANTY.

1. Mark the centre line of the pan connector on the floor for "S" trap installation or on the wall for "P" trap installation.
2. Place the pan into position centralising the pan on your centre line. Draw around the pan base and mark the entry points on the floor to where the floor fixing holes are on the side of the pan.
3. Remove the pan and drill and screw into place the floor fixing brackets. Set the floor fixing brackets 40mm inside the line drawn around the base of the pan. Use suitable floor fixing screws and toggles to suit the floor material.
4. **Critical:** The pan must be on a level surface and square to the wall. If the floor slopes away, the pan will need to be levelled using suitable floor chocks around the pan to support and stabilise the pan.
5. The standard Variance Bend supplied has a set out of 140mm to 250mm.

6. **"S" Trap Installation:** Place the Variance Bend into the floor outlet, from the finished floor to the centre of the pan outlet is 180mm. Ensure the Variance Bend is straight and square to the wall and centralised to the pan outlet height. Assemble the Variance Bend wall brace and fix to the finished wall. Measure the distance from the back edge of the pan to the "P" trap edge and add on sufficient length for the Variance Bend collar to fully engage the "P" trap.
Remove the locking ring and rubber boot from the Variance Bend. The distance between each ridge on the Variance Bend is 10mm. Once the excess has been cut off the Variance Bend, reassemble the rubber boot and locking ring.
7. Slide the pan into place being careful that full engagement of the pan Variance Bend and cistern Flush Pipe has been achieved. **N.B.** Pre-soaping the rubber boot on the Variance Bend and key seal on the Flush Pipe will assist with easier engagement.
8. Once the pan is in place and connected to the Variance Bend and Flush Pipe, screw the pan in place using the supplied fixing screws and cover.
DO NOT OVER TIGHTEN SCREWS AS THIS MAY CAUSE THE PAN TO CRACK.
9. Assemble the seat using the seat assembly instructions supplied with the seat.
10. Run a bead of neutral cure plumber's grade silicone around the pan and up the edge of the wall to finish off.

DO NOT USE OFFSET PAN COLLARS ON 'S' OR 'P' TRAP INSTALLATIONS AS THIS WILL COMPROMISE WASTE DISCHARGE. DOING SO WILL VOID THE PRODUCT WARRANTY.

IMPORTANT: Sand and debris move through water pipes. Always flush the line prior to connecting toilet suite inlet pipe to the water control valve.

CARE & MAINTENANCE

Avoid using abrasive or acid-based cleaning products.

WARRANTY

This toilet is warranted to be free from manufacturing defects for a period of:
10 years pan replacement parts and 1 year labour.
5 years cistern and seat replacement parts and 1 year labour.
1 year valves, fittings, and labour

Subject to the terms contained in the full warranty information available at <https://oliveri.com.au/service-and-warranty>, where a genuine manufacturing defect arises within the warranty period Oliveri will, at its election, repair the defect or replace the product.

This warranty does not cover against normal wear and will be voided if the product is misused or not installed in accordance with these instructions.

Our goods come with guarantees that cannot be excluded under the Australian Consumer Law. You are entitled to a replacement or refund for a major failure and for compensation for any other reasonably foreseeable loss or damage. You are also entitled to have the goods repaired or replaced if the goods fail to be of acceptable quality and the failure does not amount to a major failure.

SERVICE

If the product requires servicing, please contact your installer (preferably the one who installed it). If the plumber / installer is satisfied that the problem is not due to poor installation, contact Oliveri's nominated Warranty Service Agent for assistance on:

Ph: 08 8348 6444 (choose the after sales service and warranty option)

Email: warranty@oliveri.com.au

For full warranty information visit: <https://oliveri.com.au/service-and-warranty>

If a warranty service call finds that the product does not have a genuine manufacturing fault, our Warranty Service Agent reserves the right to pass on any call-out fee to the householder.

Oliveri Solutions Pty Ltd ABN 12 007 551 886

51 Naweena Rd, Regency Park SA 5010 P 08 8348 6444 E sales@oliveri.com.au