

Venice

Heated Towel Ladder
VE6590 Models

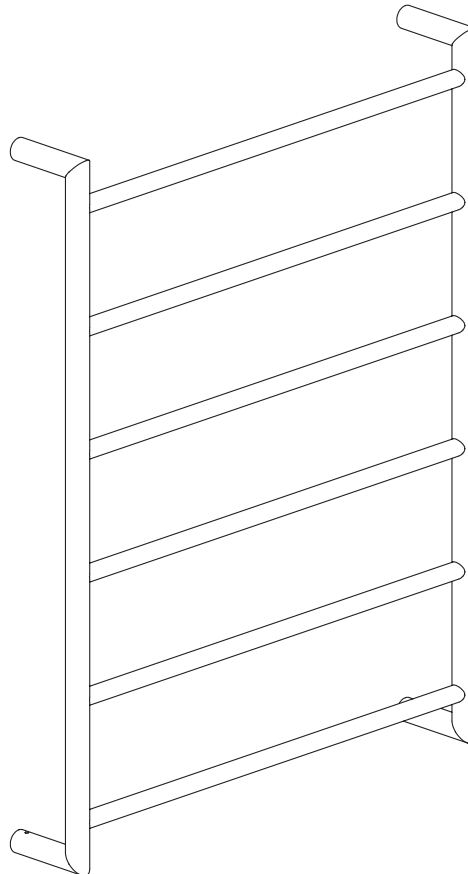





Installation Instructions

THIS PRODUCT MUST BE INSTALLED BY A LICENCED ELECTRICIAN



STOP AND READ CAREFULLY

PRE-INSTALLATION CHECKS

-  Unpack & check the item is correct and no damage has occurred during transit.
-  If there are any visible defects, **DO NOT PROCEED WITH THE INSTALLATION** and please contact the place of purchase immediately.
-  **ANY CLAIMS FOR DAMAGE WILL NOT BE ACCEPTED AFTER INSTALLATION.**
-  Protect your product before and during installation. Scratches or other surface damage sustained during or after the installation are **NOT COVERED BY WARRANTY.**
-  Installation must be in accordance with local wiring rules and regulations. Installation must be in accordance with AS/NZS 3000.
-  This product must be installed by a licenced Electrician.

TECHNICAL DETAILS

This product is manufactured to International Standards:

IEC335-1:1991
IEC60335-2-43, 1995
AS/NZS3350.1.2002

IP Rating is IP55.

WIRING INSTRUCTIONS

Green/yellow: Earth
Blue: Neutral
Brown: Phase (power)

SAFETY WARNINGS

- A qualified Electrician must install this appliance in accordance with local wiring regulations and this Instruction Manual.
- **This is a 12V heated towel rail and MUST be wired through the transformer included with the rail.**
- Ensure each rail is protected by a properly rated RCD circuit
- The provided transformer will show an output once connected to a load and only then.
- The 12V transformer must be positioned in a dry, well ventilated and accessible location.
- The maximum distance the transformer can be installed away from the rail is 2 metres.
- A means for disconnection must be incorporated into the fixed wiring in accordance with AZ/NZS 3000:2000. If connected to the supply via a three-pin plug to a fixed socket, the plug must be accessible for disconnection.
- If the power cord is damaged, the complete appliance must be returned to the Manufacturer for repair.
- This appliance will be hot to touch when turned on.
- Children should be supervised to ensure that they do not play with the appliance.
- This appliance is not intended for use by persons with reduced physical, sensory or mental capabilities, or lack of experience and knowledge, unless they have been given supervision or instruction concerning use of the appliance by a person responsible for their safety.
- Do not immerse rails in any liquid.
- Keep heating surfaces at least 100mm away from surrounding structures.
- In order to avoid a hazard for very young children, this appliance should be installed so that the lowest heated rail is at least 600mm above the floor level.

PRE-INSTALLATION NOTES

- **Installation must be performed by a licenced electrician.**
- A switched electrical supply wire must be fed through the finished wall surface.
- The heated ladder electrical wire is located at the top right hand mounting point / ladder leg.
- Install the transformer in the ceiling or wall cavity, no more than 2 metres from the rail.
- If installing in the wall cavity, ensure the transformer is behind an access plate or a timer/switch for easy access and has proper ventilation.
- The installation location must adhere to wet area guidelines in accordance with IP rating: IP55
- Connect ladder to the main power supply following local building and wiring regulations.

CARE & MAINTENANCE

Clean with a soft cloth and warm soapy water as necessary - rinse and dry after cleaning. Under no circumstances should abrasive or acid based cleaning products be used.

⚠ CAUTION

Risk of personal injury. Take safety precautions when installing electrical appliances. Be sure to use proper tools and always wear personal safety devices for your protection.

INSTALLATION STEPS

This method of connection will allow you to completely conceal the cable for your towel rail. All components required to complete this installation are included in the package. **This is a 12V heated towel rail and MUST be wired through the included transformer.**

1. Remove product from packaging and check for damage, if the product is damaged, do not install and return to store of purchase.
2. Careful read all Safety Warnings and Pre-Installation Notes in this manual before commencing installation.
3. Install the transformer in the ceiling or wall cavity, no more than 2 metres from the rails.
4. Ensure the power supply is switched off and connect the transformer to the main power supply following local building regulations. If installing in the wall cavity, ensure the transformer is behind an access plate or a timer/switch for easy access and has proper ventilation.
5. Check that the transformer receives 240V power.
6. Locate the electrical cord in the top right hand mounting point of the towel rail.
7. Hold the towel rail against the wall in the desired position and draw around each leg to mark the fixing locations on the wall. Remove the towel rail from the wall.
8. Take the 4 base plates and place them on the wall where the fixing locations are marked. Mark screw holes. NOTE: Use the A2 fixing bracket at the electrical wire connection fixing point and mark 2 holes, one for the screw hole and one for the electrical cord to pass through.
9. Using a suitable drill bit, drill holes into the mounting surface to accommodate plastic expansion sleeves at the screw hole positions drawn on the wall at each fixing point.
10. Push the plastic expansion sleeves into the drilled holes.
11. Using the screw provided, screw the A2 fixing bracket onto the wall at the electrical wire connection point.
12. Screw the remaining fixing plates (A1) onto the wall at the 3 non-electrical-cable fixing points.
13. Once all fixing plates are installed on the wall, assemble the towel rail onto the fixing brackets by aligning ladder legs to all brackets, covering the fixing brackets with the legs of the towel rail.
14. Ensure the power supply is switched off.
15. The electrical wiring cord can now be connected to the transformer through the electrical outlet fixing position, by feeding electrical wire through the A2 fixing bracket.
16. Fasten the 4 legs on to the fixing brackets by tightening the 4 grub screws, using the Allen key provided.
17. Check Product is operating correctly after installation.

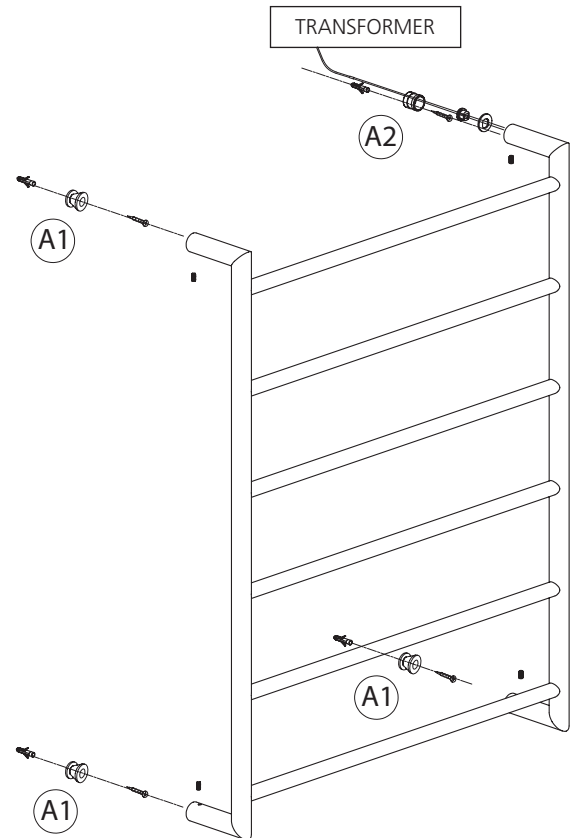

A1 indicates brackets which fix the towel rail to the wall. They are installed using METHOD 1 as shown.

A2 is the fixing bracket through which the electrical connection passes. Please install using METHOD 2 as shown.

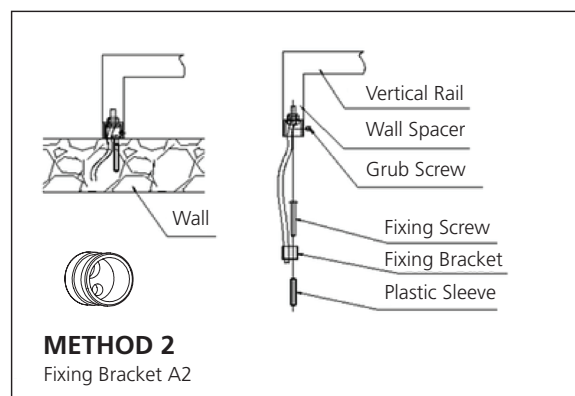
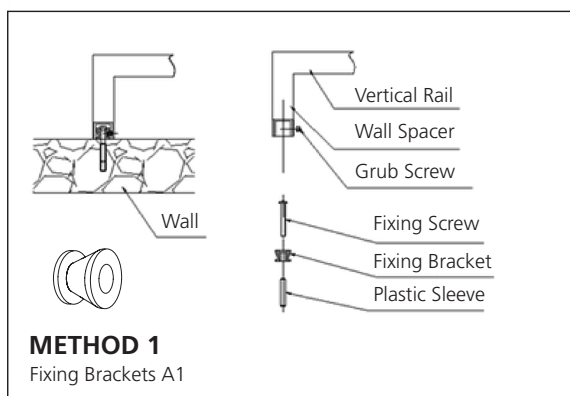

WARRANTY

We provide the following warranty for products purchased in Australia or New Zealand from authorised Oliveri resellers for use in domestic residential (indoor) or commercial (indoor) installations (Products). Commercial installations include are all non-residential installations including hotels, motels, gyms, clubs, factories, schools, hospitals, restaurants and aged care facilities. This warranty is in addition to our responsibility to customers under all other statutory and regulatory requirements. The applicable warranty period set out below (Warranty Period) starts at the original date of purchase.

PRODUCT	COMPONENT	DOMESTIC USE	COMMERCIAL USE
Bathroom Accessories	Parts	7 years replacement parts, 1 year labour	3 years replacement parts, 1 year labour
	Finish (polished & brushed stainless steel)	7 years replacement parts, 1 year labour	1 year replacement parts & labour
	Finish (other)	5 years replacement parts, 1 year labour	1 year replacement parts & labour

WARRANTY STATEMENT

(a) Our Products come with guarantees that cannot be excluded under the Australian and New Zealand consumer law. You are entitled to a replacement or refund for a major failure and for compensation for any other reasonably foreseeable loss or damage.

(b) If during the applicable Warranty Period, a Product has a material defect which arose in the course of manufacture then, subject to the warranty conditions below being met, you may submit a warranty claim to us by email or calling our Customer Care Centre:

Australia

Ph: 08 8348 6444 (select Service & Warranty option)

Email: warranty@oliveri.com.au

New Zealand

Ph: 0800 440 606 (select Service & Warranty option)

Email: warranty@oliveri.co.nz

If a warranty service call finds that the product does not have a genuine manufacturing fault, our Warranty Service Agent reserves the right to pass on any call-out fee to the householder. If we require you to return the Product, you must pay the expenses for such return.

WARRANTY CONDITIONS

We will (at our cost) either repair or replace (at our option) the Product at an equivalent value of the product purchased if it is discovered that the Product contains a material defect which arose during manufacture. We will pay the expense for shipment of the repaired or replaced Product to you. The warranty set out in the Warranty Statement above (other than sections 1(a)) is subject to the following conditions, and accordingly will not apply if:

(a) The Product was not new as at the date of purchase or proof of purchase details (such as invoice, receipt or transaction record) are not provided.

(b) There is a failure to follow installation instructions, evidence cannot be provided that the Product was installed by a licensed electrician or the Product is used other than in accordance with product specifications.

(c) Repair work is performed on the relevant Product by a person other than us, our authorised service agents or any electrician who has not received authorisation from us prior to proceeding with the work.

(d) Applicable statutes or regulations relating to public health are not observed and the Product must not have been damaged by misuse, accident or neglect.

(e) Standards or regulations governing installation are not observed.

(f) Harsh detergents or abrasive cleaners are used on any finishes of the Product.

(g) The damage is edge chipping, surface damage caused by wear and tear, cracking or discolouration due to the Product being subjected to high heat or damage caused by improper use.

(h) The Product has discolouration, natural pitting, corrosion or rusting from environmental factors.

(i) Adequate access to products, fittings and fixtures to undertake extended warranty repairs is required. We will not be responsible for any consequential damage or costs where adequate access to product fittings and fixtures is not accessible.

(j) the Product has been moved from original installations.

Oliveri Solutions Pty Ltd ABN 12 007 551 886

For more information or any questions about this warranty, contact us or visit our website.

Australia

51 Naweena Rd, Regency Park SA 5010

P: 08 8 348 6444

E: sales@oliveri.com.au

oliveri.com.au

New Zealand

PO Box 4641 Christchurch 8140

P: 0800 440 606

E: sales@oliveri.co.nz

oliveri.co.nz