

# Venice

## VE523FCR

### Chrome Goose Neck 3 Way Filter Tap

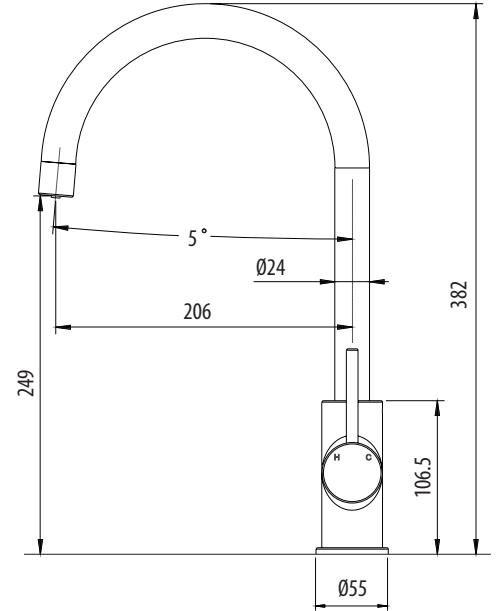

### Specifications /

<b>WELS rating</b>	5 Stars, 6.0 L per minute
<b>WELS registration number</b>	T46532
<b>Temperature rating (min / max)</b>	1°C - 80°C
<b>Pressure rating (min / max)</b>	150 kPa - 500 kPa
<b>Finish</b>	Chrome (Electroplate)
<b>Materials</b>	Lead free brass body
<b>Cartridge size</b>	35 mm (mains)
<b>Cartridge type</b>	Ceramic disc cartridge
<b>Filtered water inlet</b>	1/4"
<b>Inlet hose length</b>	400 mm
<b>Carton size</b>	540 x 300 x 60 mm
<b>Product weight</b>	2.7 kg
<b>Mixer height</b>	382 mm
<b>Water supply</b>	Mains
<b>Warranty</b>	10 years (see Oliveri website for full details)
<b>Maintenance and care instructions</b>	All surfaces should be cleaned with mild liquid detergent or soap and water. Do not use cream cleaners or citrus based cleaning products, as they are abrasive. Use of unsuitable cleaning agents may damage the surface. Any damage caused in this way will not be covered by warranty.