

Oliveri®

SPB0227/SPB0228/SPB0252/SPB0254/SPB0256

SPB0227 Care Handle - 25mm Pin lever Chrome suits

VE103500CR Venice Chrome Curved Basin Mixer
 VE104500CR Venice Chrome Curved Tower Basin Mixer
 VE106500CR Venice Chrome Straight Basin Mixer
 VE107500CR Venice Chrome Straight Tower Basin Mixer
 VE109500CR Venice Chrome Uplift Basin Mixer
 VE110500CR Venice Chrome Uplift Tower Basin Mixer

SPB0228 Care Handle - 25mm Pin lever Matte black suits

VE103506MB Venice Matte Black Curved Basin Mixer
 VE104506MB Venice Matte Black Curved Tower Basin Mixer
 VE106506MB Venice Matte Black Straight Basin Mixer
 VE107506MB Venice Matte Black Straight Tower Basin Mixer
 VE109506MB Venice Matte Black Uplift Basin Mixer
 VE110506MB Venice Matte Black Uplift Tower Basin Mixer

SPB0252 Care Handle - 25mm Pin lever Brushed Nicke suits

VE103504BN Venice Brushed Nicke Curved Basin Mixer
 VE104504BN Venice Brushed Nicke Curved Tower Basin Mixer
 VE106504BN Venice Brushed Nicke Straight Basin Mixer
 VE107504BN Venice Brushed Nicke Straight Tower Basin Mixer
 VE109504BN Venice Brushed Nicke Uplift Basin Mixer
 VE110504BN Venice Brushed Nicke Uplift Tower Basin Mixer

SPB0254 Care Handle - 25mm Pin lever Gunmetal suits

VE103505GM Venice Gunmetal Curved Basin Mixer
 VE104505GM Venice Gunmetal Curved Tower Basin Mixer
 VE106505GM Venice Gunmetal Straight Basin Mixer
 VE107505GM Venice Gunmetal Straight Tower Basin Mixer
 VE109505GM Venice Gunmetal Uplift Basin Mixer
 VE110505GM Venice Gunmetal Uplift Tower Basin Mixer

SPB0256 Care Handle - 25mm Pin lever Classic Gold suits

VE103503CG Venice Classic Gold Curved Basin Mixer
 VE104503CG Venice Classic Gold Curved Tower Basin Mixer
 VE106503CG Venice Classic Gold Straight Basin Mixer
 VE107503CG Venice Classic Gold Straight Tower Basin Mixer
 VE109503CG Venice Classic Gold Uplift Basin Mixer
 VE110503CG Venice Classic Gold Uplift Tower Basin Mixer

Oliveri®

SPB0229/SPB0230/SPB0253/SPB0255/SPB0257

SPB0229 Care Handle - 35mm Pin lever Chrome suits

VE112500CR Venice Chrome Wall Mixer with Diverter
 VE105500CR Venice Chrome Curved Wall Mixer Set
 VE108500CR Venice Chrome Straight Wall Mixer Set
 VE111500CR Venice Chrome Wall Mixer

SPB0230 Care Handle - 35mm Pin lever Matte black suits

VE112516MB Venice Matte Black Wall Mixer with Diverter
 VE105516MB Venice Matte Black Curved Wall Mixer Set
 VE108516MB Venice Matte Black Straight Wall Mixer Set
 VE111516MB Venice Matte Black Wall Mixer

SPB0253 Care Handle - 35mm Pin lever Brushed Nicke suits

VE112504BN Venice Brushed Nicke Wall Mixer with Diverter
 VE105504BN Venice Brushed Nicke Curved Wall Mixer Set
 VE108504BN Venice Brushed Nicke Straight Wall Mixer Set
 VE111504BN Venice Brushed Nicke Wall Mixer

SPB0255 Care Handle - 35mm Pin lever Gunmetal suits

VE112505GM Venice Gunmetal Wall Mixer with Diverter
 VE105505GM Venice Gunmetal Curved Wall Mixer Set
 VE108505GM Venice Gunmetal Straight Wall Mixer Set
 VE111505GM Venice Gunmetal Wall Mixer

SPB0257 Care Handle - 35mm Pin lever Classic Gold suits

VE112503CG Venice Classic Gold Wall Mixer with Diverter
 VE105503CG Venice Classic Gold Curved Wall Mixer Set
 VE108503CG Venice Classic Gold Straight Wall Mixer Set
 VE111503CG Venice Classic Gold Wall Mixer

CARE & MAINTENANCE

Clean with a soft cloth and warm soapy water as necessary - rinse and dry after cleaning. Under No Circumstances should abrasive or acid based cleaning products be used.

PARTS LIST

No.	Description	Qty
A	Care handle	1
B	Grub screw	1
C	Allen key	1

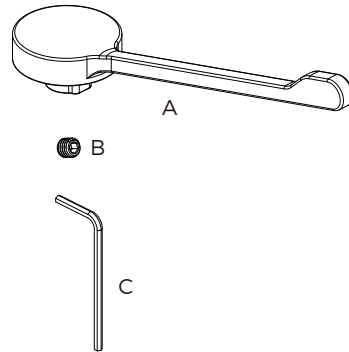

PLUMBERS INSTALLATION INSTRUCTIONS

Disassembly

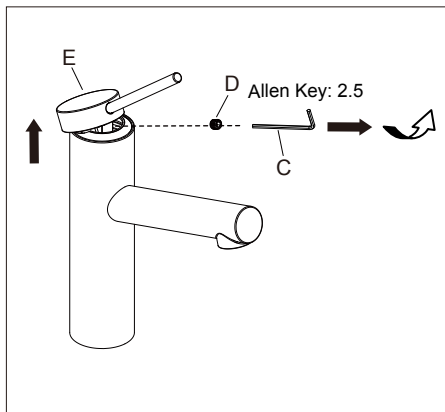

Assembly

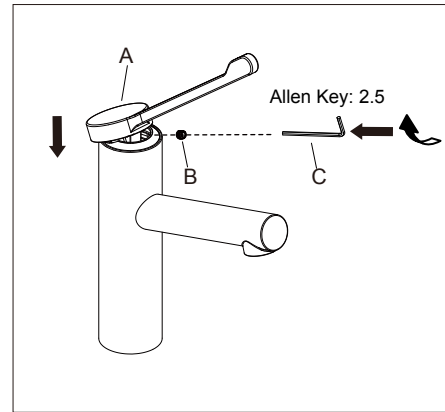

Replacing Handle

Disassembly: Using a 2.5mm allen key (C) to loosen grub screw (D) and remove handle (E).

Assembly: Fit new handle (A), taking care that it is pushed fully onto cartridge stem, and use a 2.5mm allen key (C) to lock the grub screw (B) tightly.

WARRANTY

PRODUCT	COMPONENT	DOMESTIC USE	COMMERCIAL USE
Care Handle	Finish (chrome) SPB0227 SPB0229	15 years replacement parts, 1 year labour	1 year replacement parts & labour
	Finish (PVD) SPB0252 SPB0253	10 years replacement parts, 1 year labour	1 year replacement parts & labour
	Finish (other) SPB0254 SPB0255 SPB0256 SPB0257 SPB0228 SPB0230	5 years replacement parts, 1 year labour	1 year replacement parts & labour

Subject to the terms contained in the full warranty information available at <https://oliveri.com.au/service-and-warranty>, where a genuine manufacturing defect arises within the warranty period Oliveri will, at its election, repair the defect or replace the product.

This warranty does not cover against normal wear and will be voided if the product is misused or not installed in accordance with these instructions.

Our goods come with guarantees that cannot be excluded under the Australian Consumer Law. You are entitled to a replacement or refund for a major failure and for compensation for any other reasonably foreseeable loss or damage. You are also entitled to have the goods repaired or replaced if the goods fail to be of acceptable quality and the failure does not amount to a major failure.

SERVICE

If the problem represents a danger, or damage to property may occur, immediately shut off the water supply.

If the product requires servicing, please contact your plumber / Installer (preferably the one who installed it). If the Plumber / Installer is satisfied that the problem is not due to poor installation, contact Oliveri's nominated Warranty Service Agent for assistance on:

Ph: (08) 8348 6444 (choose the after sales service & warranty option)

Email: warranty@oliveri.com.au

For full warranty information visit: <https://oliveri.com.au/service-and-warranty>

If a warranty service call finds that the spout does not have a genuine manufacturing fault, our Warranty Service Agent reserves the right to pass on any call-out fee to the householder.