

# Nu-Petite

NP601

1 & 1/2 Bowl Topmount Sink With Drainer



All dimensions in mm

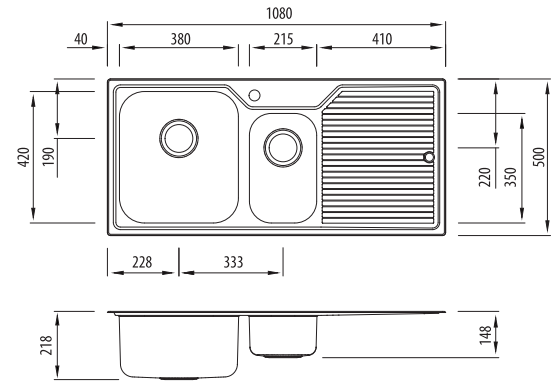

## Specifications /

<b>Sink size</b>	1080W x 500H mm
<b>Bowl size</b>	Main Bowl 380W x 420H x 200D / 30L 1/2 Bowl 215W x 350H x 130D / 9L
<b>Construction</b>	2 piece, bowls and drainer seam welded
<b>Material</b>	304 grade, 18/10 polished stainless steel (0.8 mm thick)
<b>Installation</b>	Topmount
<b>Fixings</b>	Adjustable clips and sealing foam supplied
<b>Min cabinet size</b>	700 mm
<b>Tap holes</b>	Available 0 or 1 tap hole (specify when ordering)
<b>Waste fittings</b>	2 x 90 mm basket wastes included
<b>Overflow</b>	Not available
<b>Carton size</b>	1267 x 567 x 237 mm
<b>Weight</b>	8 kg
<b>Warranty</b>	Lifetime manufacturer's warranty (refer to <a href="http://oliveri.com.au">oliveri.com.au</a> )
<b>Maintenance and care instructions</b>	All surfaces should be cleaned with mild liquid detergent or soap and water. To maintain the shine on your Oliveri stainless steel sink, we recommended the use of any of the easy to obtain, non-abrasive stainless steel cleaners or metal polishes.

## Included accessories /

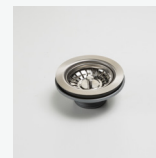

**AC14**  
Basket Waste

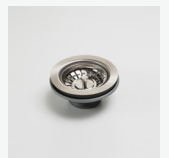

**AC14**  
Basket Waste



**AC65**  
Bamboo Board



**AC6220**  
Colander

