



THIS MIXER TAP MUST BE INSTALLED BY A LICENSED PLUMBER IN ACCORDANCE WITH LOCAL REGULATIONS

This Oliveri tap is manufactured to standard AS/NZS 3718.

MAX OPERATING PRESSURE:.....5 bar (500kPa)
 RECOMMENDED OPERATION PRESSURE:.....1.5-5 bar (150-500kPa)
 MAX HOT WATER TEMPERATURE:.....65°C
 RECOMMENDED HOT WATER TEMPERATURE:.....50°C

Where water pressure exceeds 500kPa, a pressure reducing device is required to be installed. Note that water pressure overnight can reach 150% of the daytime pressure.

Note: Ceramic Cartridges - Warranty claims will not be honoured where the ceramic cartridge has malfunctioned due to the presence in the water supply of;

- Copper tube pieces, sand, dirt or stones
- Thread tape
- Other objects not normally present in potable water supplies.
- Do not remove the cartridge from the body as it has been pressure tested and tightened to a specific torque.

Before attempting any work involving mains water supply lines, ensure the water supply is shut off. This mixer tap must be installed in accordance with these instructions.



VE111500CR/VE111516MB/VE111504BN
 /VE111503CG/VE111505GM



Venice Bath or Shower Mixer

CARE & MAINTENANCE

Clean with a soft cloth and warm soapy water as necessary - rinse and dry after cleaning. Under No Circumstances should abrasive or acid based cleaning products be used.

WARRANTY

PRODUCT	COMPONENT	DOMESTIC USE	COMMERCIAL USE
Bathroom Tapware Excludes Sensor Taps	Cartridge	15 years replacement parts, 1 year labour	7 years replacement parts, 1 year labour
	Body	15 years replacement parts, 1 year labour	5 years replacement parts, 1 year labour
	Finish (chrome) VE111500CR	15 years replacement parts, 1 year labour	1 year replacement parts & labour
	Finish (PVD) VE111504BN	10 years replacement parts, 1 year labour	1 year replacement parts & labour
	Finish (other) VE111516MB VE111503CG VE111505GM	5 years replacement parts, 1 year labour	1 year replacement parts & labour
	Seals, tails, fittings & aerators	5 years replacement parts, 1 year labour	1 year replacement parts & labour

Subject to the terms contained in the full warranty information available at <https://oliveri.com.au/service-and-warranty>, where a genuine manufacturing defect arises within the warranty period Oliveri will, at its election, repair the defect or replace the product.

This warranty does not cover against normal wear and will be voided if the product is misused or not installed in accordance with these instructions.

Our goods come with guarantees that cannot be excluded under the Australian Consumer Law. You are entitled to a replacement or refund for a major failure and for compensation for any other reasonably foreseeable loss or damage. You are also entitled to have the goods repaired or replaced if the goods fail to be of acceptable quality and the failure does not amount to a major failure.

SERVICE

If the problem represents a danger, or damage to property may occur, immediately shut off the water supply.

If the product requires servicing, please contact your plumber / Installer (preferably the one who installed it).

If the Plumber / Installer is satisfied that the problem is not due to poor installation, contact Oliveri's nominated Warranty Service Agent for assistance on:

Ph: (08) 8348 6444 (choose the after sales service & warranty option)

Email: warranty@oliveri.com.au

For full warranty information visit: <https://oliveri.com.au/service-and-warranty>

If a warranty service call finds that the spout does not have a genuine manufacturing fault, our Warranty Service Agent reserves the right to pass on any call-out fee to the householder.

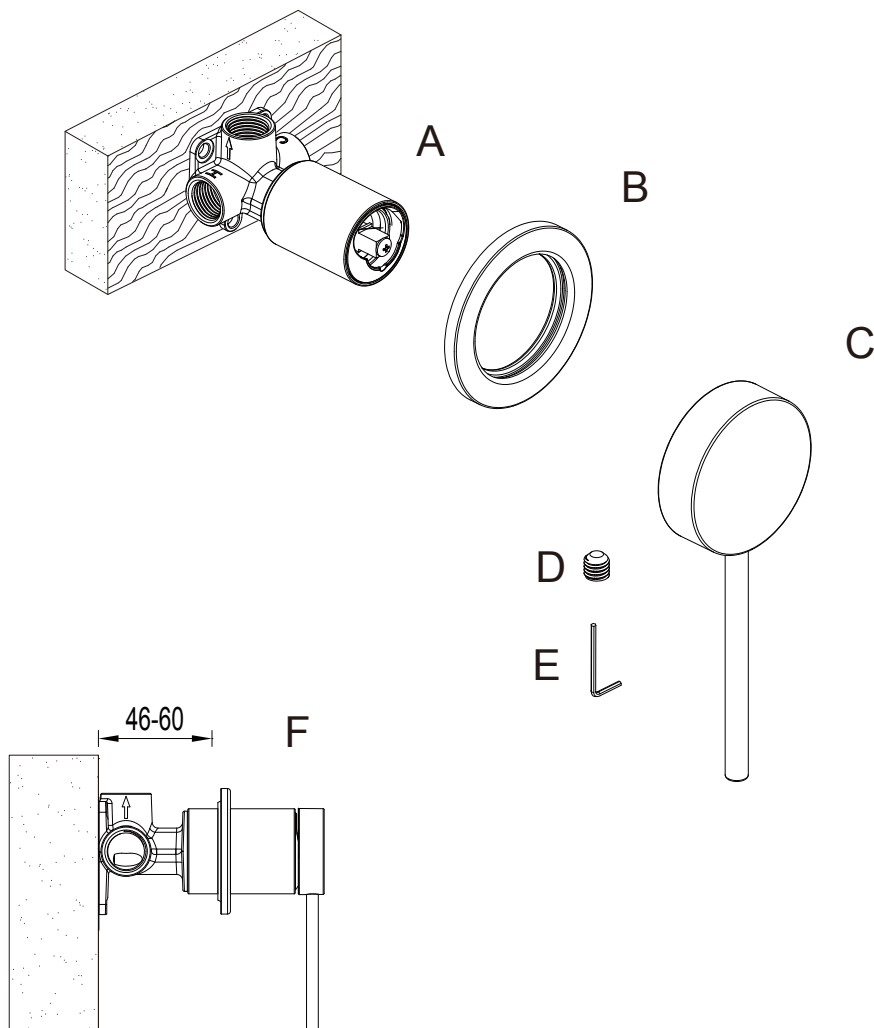

Oliveri®

Installation Instructions

General Note: This product is to be installed by a licensed plumber, installation must comply with AS/NZS 3500 and local plumbing codes.

Pressures & Temperatures

Maximum Hydrostatic Pressure – 500 kpa. (As per AS/NZS3500)

Note: AS/NZS 3500.1-2003 (Clause 3.3.4) states that "Provision shall be made to ensure that the maximum static pressure at any outlet, other than a fire service outlet, within a building does not exceed 500 kPa."

Note: Pressures above 500kPa can cause damage from water hammer, reduced life of appliances, taps and fittings, and cause excessive noise in the system.

Minimum Hydrostatic Pressure – 100 kpa

The Maximum operating temperature for the Mixer Tap is 65°C.

Please ensure that the lines are flushed prior to installation as contaminates in the water can damage the Ceramic Cartridge and also affect the performance of the Mixer.

1. Remove product from packaging and check for damages, if the product is damaged do not install and return to store of purchase.
 2. Ensure Product is complete as per exploded drawing.
 3. All Shower and Shower Divertor Mixers are supplied with Plastic Protection Body covers, ensure the body cover is on the mixer body and push pull dial on divertor Mixers prior to installation.
 4. Screw Mixer Body (A) to the Stud Wall or Brick Cavity taking into account set out minimum and maximum from back of Mixer to Finished Wall (F).
 5. Install Water supply to Mixer body, Left (Hot), Right (Cold) as per AS3500 and Local Authority requirements.
 6. Install water supply lines for shower and/or bath outlets.
- N.B Shower/Bath Mixers (Not Divertor Mixers) are a 3 Port Body, for Bath installation loop the copper pipe to the underside of the mixer for bath installation. DO NOT turn Mixer upside down as the Mixer will not function correctly.**
7. Once wall sheeting and tiles have been fitted seal around the Mixer body with plumbers grade silicon or sealing compound.
 8. Slide Mixer Wall plate in Place (B) N.B Shower/Bath Wall Plates and Shower & Bath Divertor Wall plates are fitted with concealed sealing washers, to assist with assembly of the wall plate onto the mixer body apply soapy water or plumbers grade grease to the concealed sealing washers.
 9. Fit Mixer Handle (C).
 10. Screw in Handle Grub Screw (D) using allen key (E)
 11. N.B Some Grub Screw covers are also Hot and Cold indicators, ensure when fitting a Grub screw cover on the handle that has the hot and cold indicators that the Red (Hot) is on the left hand side.

To the consumer

1. The Mixer is to only be cleaned with warm soapy water.
2. **Under No Circumstances** should any abrasive, cream or acid based cleaning agents be used as these types of cleaners will damage the finish, Cartridge and seals.